

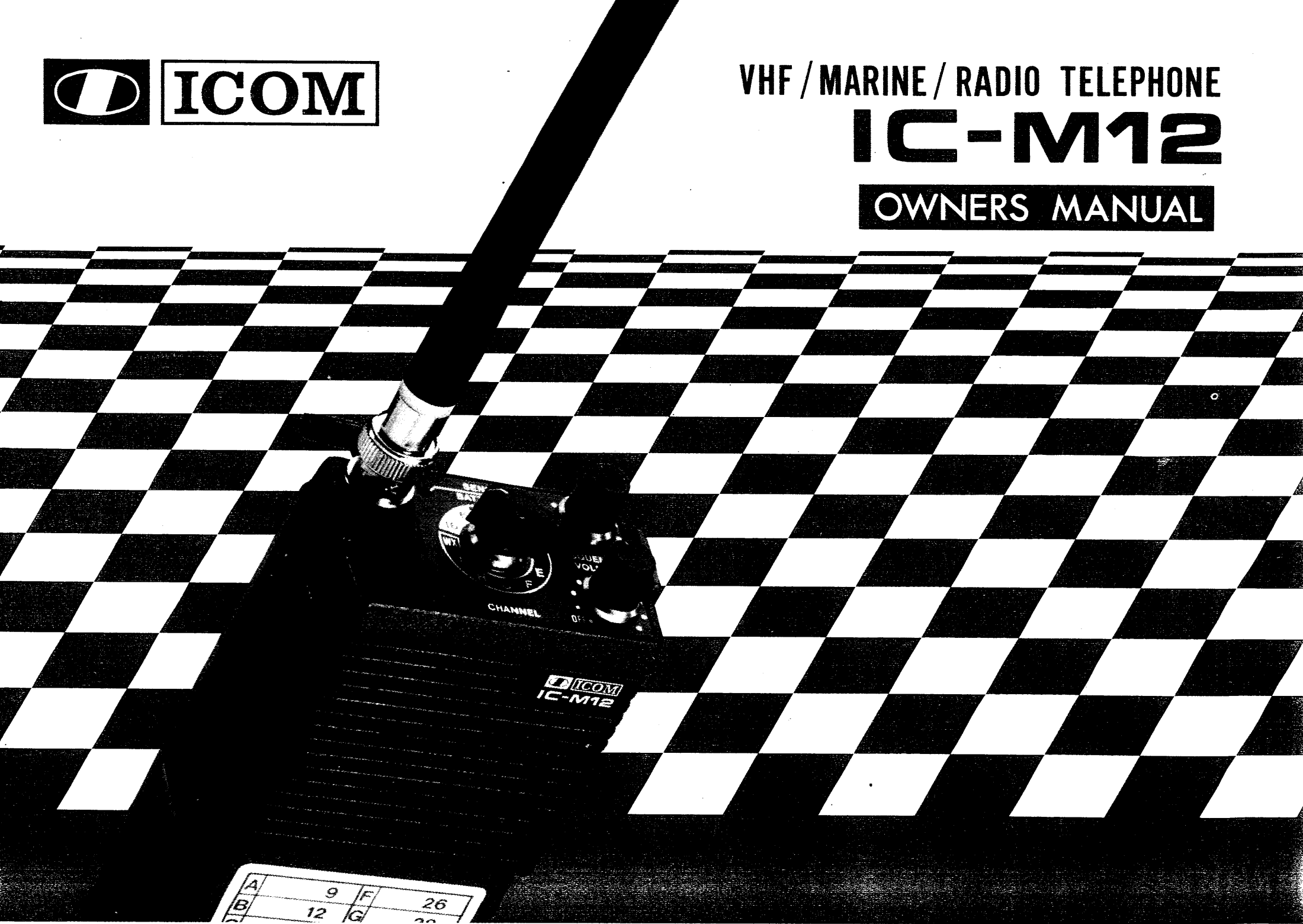

VHF / MARINE / RADIO TELEPHONE

# IC-M12

OWNERS MANUAL



A	9	F	26
B	12	G	28

## TABLE OF CONTENTS

I. INTRODUCTION .....	1
II. SPECIFICATIONS .....	2
III. ACCESSORIES.....	4
IV. PRE-OPERATION .....	5
V. CONTROL FUNCTIONS.....	12
VI. OPERATION .....	16
VII. OPERATING RULES AND GUIDELINES .....	18
VIII. MARINE VHF RADIOTELEPHONE CHANNEL FREQUENCIES .....	21
IX. TRANSMITTER LOG .....	23
X. EMERGENCY USE .....	25

## **SECTION I INTRODUCTION**

### **SYNTHESIZED HAND HELD TRANSCEIVER**

The ICOM IC-M12 is a very compact VHF synthesized hand held transceiver. Using the latest in electronic design, the IC-M12 offers diode programming for frequency selection, eliminating the need, expense and delay in changing the channel configuration. Channels are easily installed or changed, any time, at your marine dealer, by changing diode positions on the matrix board. Offering rugged construction, extreme stability and frequency accuracy, the IC-M12 will give you years of troublefree operation.

### **VARIOUS POWER PACKS AVAILABLE**

The Power Pack is slipped on the bottom of the radio very easily, and various power packs are available to suit your needs, for minimum size or longer use.

### **HIGHLY EFFICIENT FLEXIBLE ANTENNA**

A highly efficient flexible antenna is supplied with the set. When the antenna is removed, its connector can be used for an external antenna connector.

## SECTION II SPECIFICATIONS

### GENERAL

Number of Semiconductors	Transistors	41
	FET	3
	IC	5
	Diodes	15 (not including diodes on the matrix board)
Number of Channels	12 programmable channels	
	Operation Simplex, Semi-duplex	
Channel Spacing	25 KHz	
Frequency Stability	0.0005 Percent	
Usable Temperature	-20 Degrees C to 60 Degrees C (-4 Degrees F to 140 Degrees F)	
Antenna Impedance	50 ohms unbalanced	
Power Supply Requirement	DC 8.4V; with attendant power pack IC-CM3, DC 6 to 12V negative ground is acceptable	
Current Drain at 8.4V	Transmitting	
	At 1 watt output	Approx. 350mA
	Receiving	
	At max audio output	Approx. 130mA
	Squelched	Approx. 25mA
Dimensions	116.5mm(H) x 65mm(W) x 45mm(D) without power pack Attendant power pack, IC-CM3: 49mm(H) x 65mm(W) x 35mm(D)	
Weight	510g including power pack, IC-CM3 and flexible antenna	

## RECEIVER

Frequency Range	156.3 ~ 157.425MHz and 160.875 ~ 162.550MHz
Receiving System	Double-conversion superheterodyne
Modulation Acceptance	16F <sub>3</sub> ±7.5KHz
Intermediate Frequency	1st: 10.695MHz 2nd: 455KHz
Sensitivity	Less than 0.5μV for 20dB Noise quieting Less than 0.4μV for 12dB SINAD
Squelch Sensitivity	Less than 0.4μV
Spurious response rejection ratio	More than 50dB
Selectivity	More than 65dB at adjacent channel
Intermodulation Rejection Ratio	More than 60dB
Audio Output Power	More than 300mW at 10% distortion
Audio Output Impedance	8 ohms

## TRANSMITTER

Frequency Range	156.3 ~ 157.425MHz
Output Power	1 Watt
Emission Mode	16F <sub>3</sub>
Modulation System	Variable reactance frequency modulation
Max. Frequency Deviation	±5KHz
Spurious Emission	More than 57dB below carrier
Microphone	Built-in Electret condenser microphone Optional Speaker-microphone (IC-CM9) can be used

## SECTION III ACCESSORIES

Carefully remove your transceiver from the packing carton and examine it for signs of shipping damage. Should any be apparent, notify the delivering carrier or dealer immediately, stating the full extent of the damage. It is recommended that you keep the shipping cartons. In the event storage, moving, or reshipment becomes necessary, they come in handy. Various accessories are packed with the transceiver. Make sure you have not overlooked anything.

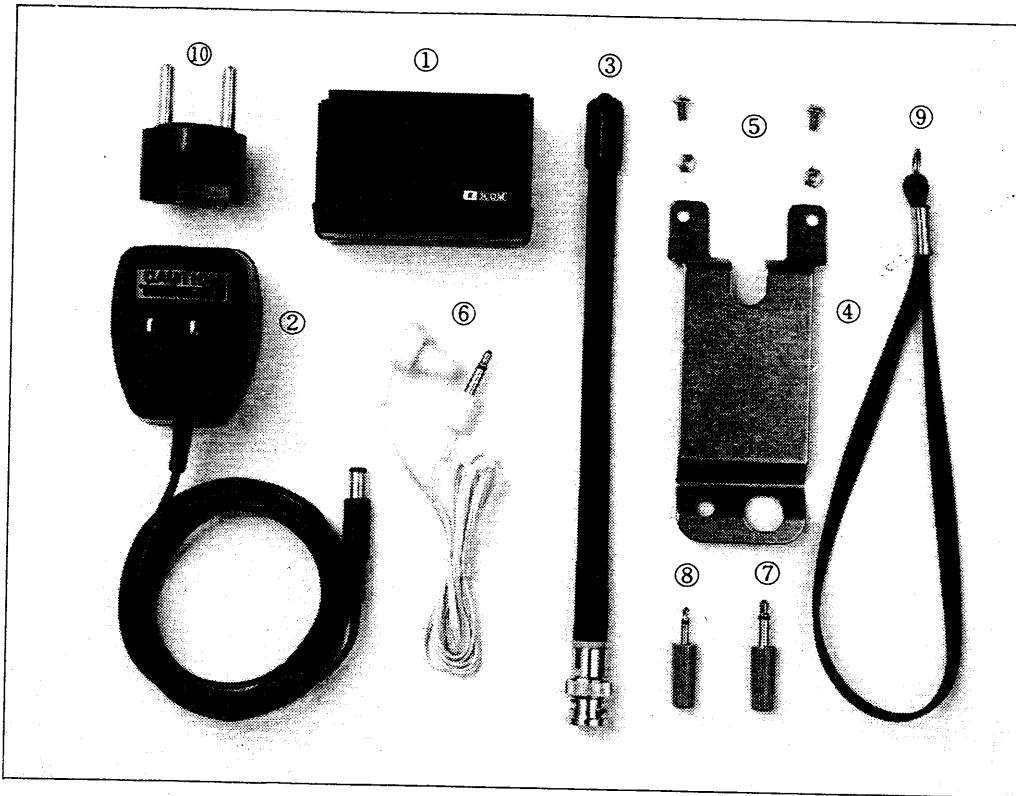

- |  |   |
|--|---|
| 1. Power pack IC-CM3 . . . . .         | 1 |
| (attached to the set)                  |   |
| 2. Wall charger CM-25U/E . . . . .     | 1 |
| 3. Flexible antenna . . . . .          | 1 |
| 4. Belt clip. . . . .                  | 1 |
| 5. Belt clip retaining screws. . . . . | 2 |
| 6. Earphone. . . . .                   | 1 |
| 7. Earphone plug . . . . .             | 1 |
| 8. Microphone plug. . . . .            | 1 |
| 9. Hand-strap. . . . .                 | 1 |
| 10. AC conversion plug** . . . . .     | 1 |
- \* CM-25U for 117V AC  
 CM-25E for 240V AC  
 \*\* 117V AC version is not included.

## SECTION IV PRE-OPERATION

### BATTERY INSTALLATION

#### When using Nickel-Cadmium power pack IC-CM3:

The IC-CM3 is a rechargeable Nickel-Cadmium power pack, and it can be slipped onto or off of the set very easily. It has a connector for a charger current control circuit, reverse polarity protection circuit and charge indicator LED in its own pack. You can use the supplied CM-25U/E wall charger or similar simple wall charger, or a 12V battery by using optional cable IC-CM1 for recharging. Before use, the power pack should be charged about 15 hours, because the battery may have discharged.

After charging is completed, the batteries can be used in the same manner as dry cells. However, the voltage of Nickel-Cadmium batteries drops rapidly just before they are exhausted, so when the Transmit Indicator LED of the transceiver goes out, be sure to immediately stop using it, and recharge the batteries again.

#### HOW TO CHARGE (When using Nickel-Cadmium power pack IC-CM3)

1. Use the supplied wall charger CM-25U/E or a stable power source with an output voltage of 13.8V DC and current capacity over 50mA, or use a 12V battery with optional charger cable IC-CM1. (Output voltage of 12 ~ 15V can be used, but output voltage near the specified voltage should be used.)
2. The power switch of the transceiver must be OFF, or remove the power pack from the transceiver.

3. Connect the output plug of the wall charger (CM-25U/E), or other power source, to the charger socket of the power pack. (When charging Nickel-Cadmium batteries in the IC-CM4 power pack, you should use the CM-30 charger only.)

The charge indicator LED of the power pack is lit, which shows that the charger is working.

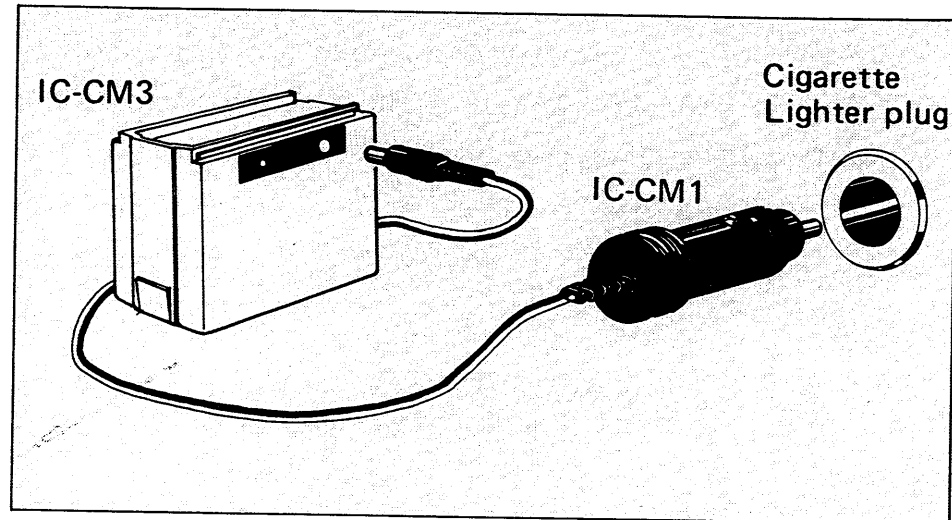
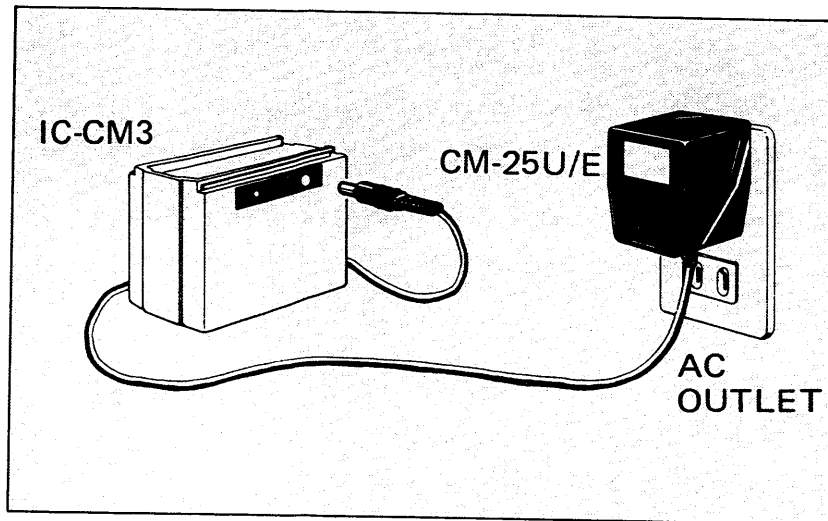

4. It takes about 15 hours to charge the batteries completely. This charger is designed for 0.1C (10-hour rate current), but charge for 15 hours in order to compensate for any unbalance of the batteries.

You should charge the batteries for 15 hours when you have not used them for a long time or after buying them.

5. Charge between 0°C and 40°C.
6. Avoid continuing charging as much as possible after full charging, (15 hours). If excess charging is repeated, efficiency of the power pack is reduced.
7. After charging, unplug the power source from the charger socket of the power pack. The transceiver and the power pack are now ready for operation.



# PRECAUTIONS FOR USE OF THE NICKEL-CADMIUM BATTERIES

(from the JIS C8705 MANUAL)

## General Cautions

1. Never short the power pack.  
Since internal resistance is low, excess shorted current flows away, causing the batteries or conductors to burn. Avoid shorts! A label showing polarity is on the power pack.
2. Never solder the batteries directly.  
If the batteries are soldered directly, the separator or insulator may become melted and damaged. Accordingly, the terminal must be spot-welded first and then soldered.
3. Confirm polarities in order to prevent reverse charging.  
If they are charged in reverse, batteries may be damaged. Therefore confirmation of correct polarity is essential, to proper operation.
4. Never charge with excess charging current.  
If an excess charging rate is employed, gas consumption speed cannot keep up with gas generating speed at the time of charging. Batteries may be damaged by increasing internal pressure. Accordingly, the charging must be kept regulated.
5. Avoid charging under 0°C or over 40°C.  
Under 0°C, since gas consumption speed becomes lower at the charging time, inside pressure increases and hydrogen is generated. Since charging efficiency is reduced over 40°C, it is rather difficult to charge. Accordingly, charging must be done between 0°C and 40°C.
6. Never put batteries into fire.  
Since there may be a little gas left in the batteries, internal pressure increases suddenly and the batteries explode if thrown into a fire. Also, battery electrolyte is ejected and can cause damage to skin and clothes.

When using the alkaline power pack IC-CM 4:

Place the power switch in the OFF position. Remove the power pack from the bottom of the set by pushing the pack in the indicated direction. Separate the pack into two parts (cases) as follows:

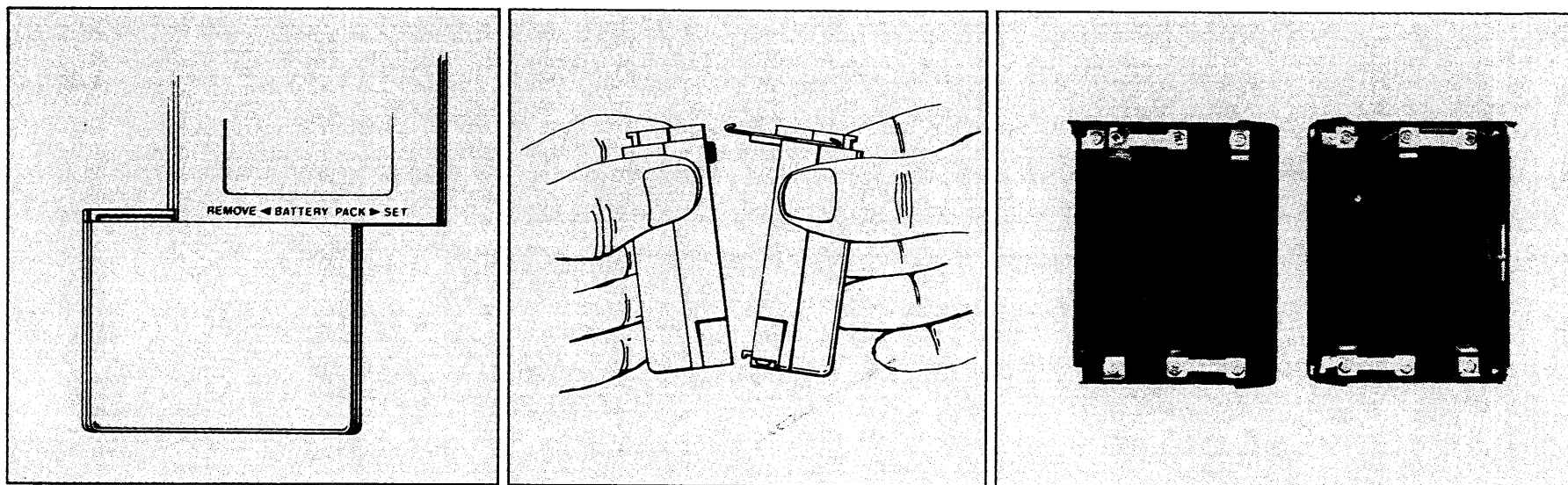

Each case holds three AA type batteries. Install batteries into each case, according to indicated polarity. With the batteries properly in place, carefully replace the pack and slip it onto the set with the reverse procedure.

Also, AA type Nickel-Cadmium, rechargeable, batteries can be used. But the charger for them should be the optional CM-30 charger.

## WHEN TO REPLACE BATTERIES (When using alkaline batteries)

When the Transmit Indicator LED does not light up during transmission, the batteries are exhausted. Use batteries of the same type, for mixed types might cause leakage. Replace worn batteries with a complete new set. If used with old batteries, the life of new ones might be shortened. Battery life is shortened more by transmitting than by receiving, since several times more current is drawn during transmission. To prolong battery life, therefore, practice the following:

- \* Try to minimize the transmit period.
- \* Reduce volume during reception.
- \* Be sure to cut off power source when set is not used.

More working hours are available if high-performance batteries are employed.

## FOR USE

1. Attach the supplied power pack. (Refer to "BATTERY INSTALLATION")
2. Attach the supplied hand strap and belt clip through the fixture on the body (as shown in the drawings on page 10.)
3. Attach the flexible rubber antenna or connect an external antenna.

## EXTERNAL ANTENNA

1. Select a high performance antenna and set it up in the highest possible position.
2. Use a 50 ohm antenna and coaxial cable.
3. On VHF, the power loss in the antenna cable is large, so use a cable with the lowest possible loss and make it as short as possible.
4. Use a BNC plug for connection to the unit.

## ATTACHMENT OF HAND STRAP AND BELT CLIP

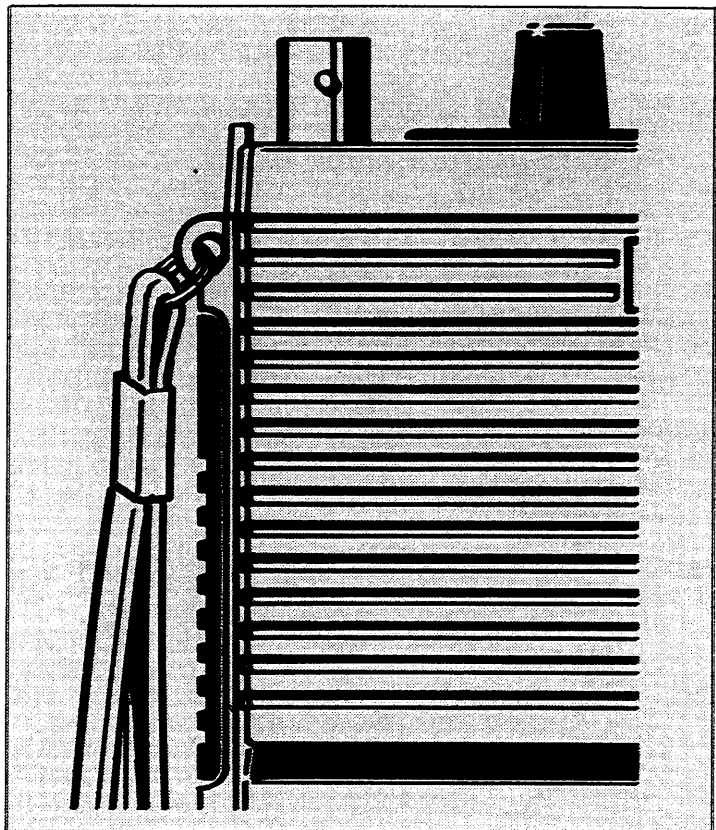

- Attach the belt clip on the back cover with the 2 screws supplied.

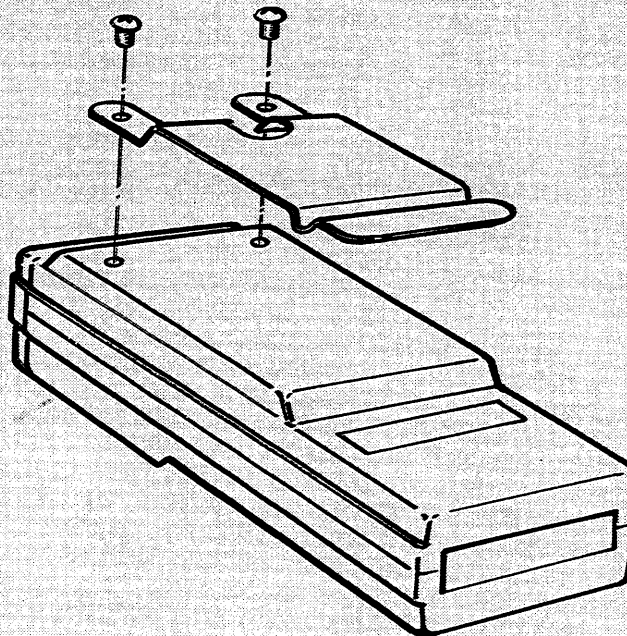

## CHANGE OR ADDITION OF CHANNELS

The design of your ICOM Marine Radiotelephone provides an inexpensive means for expanding channel capability. The services of a dealers technician is required for installation and alignment. The additional channel(s) you require may be placed anywhere on the dial you choose. Additional weather channels can also be installed on the channels G, H, I and WX.

## LICENSES REQUIRED

### 1. Ship Station License

Your craft, when equipped with VHF/FM equipment, has a radio station on board which, if used, must have a current license. It is unlawful to operate a Ship Station which is not licensed. Inquire through your dealer or appropriate government agency for an application for a Ship Radio-Telephone license. Your craft station will be issued a call sign.

### 2. Operators License

A Restricted Radiotelephone Operator Permit is the license most often held by small vessel radio operators if a radio is not required for safety purposes. You can usually obtain this permit by mail without examination. Again, contact your marine dealer or appropriate government agency for information or application.

The Restricted Radiotelephone Operator Permit must be posted or kept on the person of the operator. Only a licensed radio operator may operate a radiotelephone transmitter. However, non-licensed individuals may talk over a radiotelephone if a licensed operator starts, supervises, ends the call, and makes necessary log entries.

A current copy of the appropriate government agency rules and regulations is usually required to be kept.

## LOGS AND DOCUMENTS

Most countries require that a log of all contacts made over the Radiotelephone be kept. The Ship Radiotelephone Station licensee is the person responsible for compliance.

# SECTION V CONTROL FUNCTIONS

## TOP PANEL

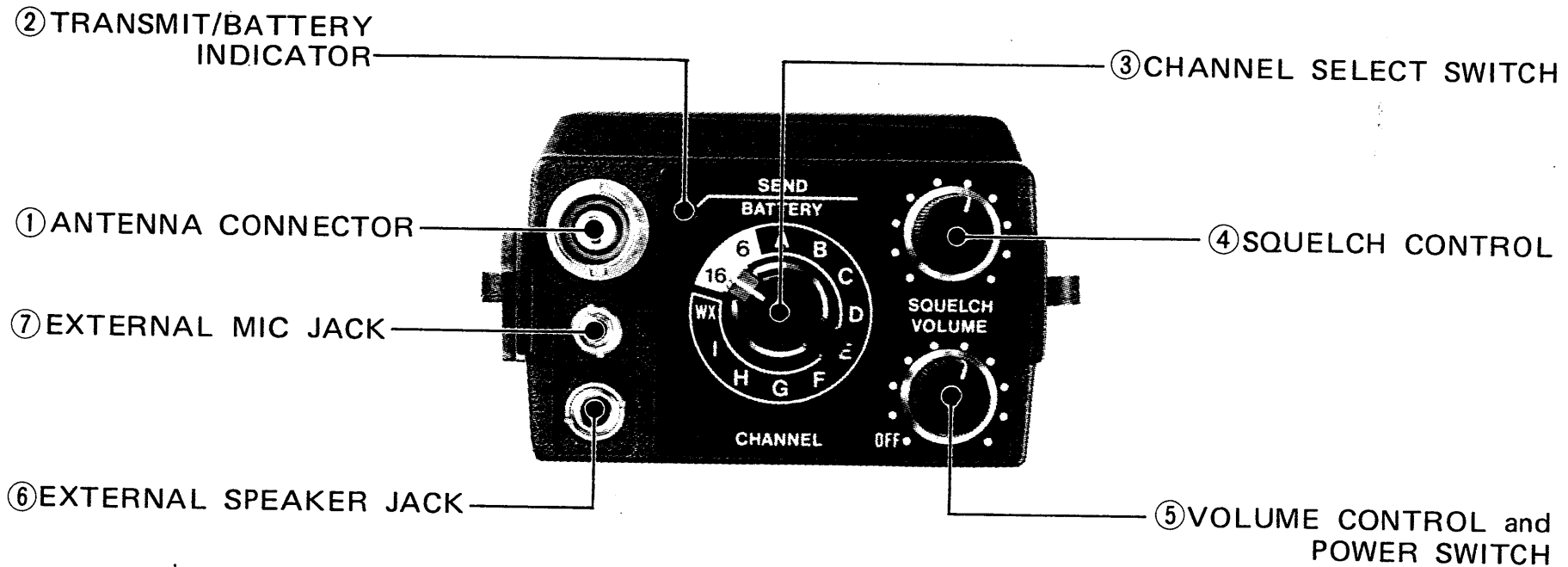

# FRONT PANEL

# REAR PANEL

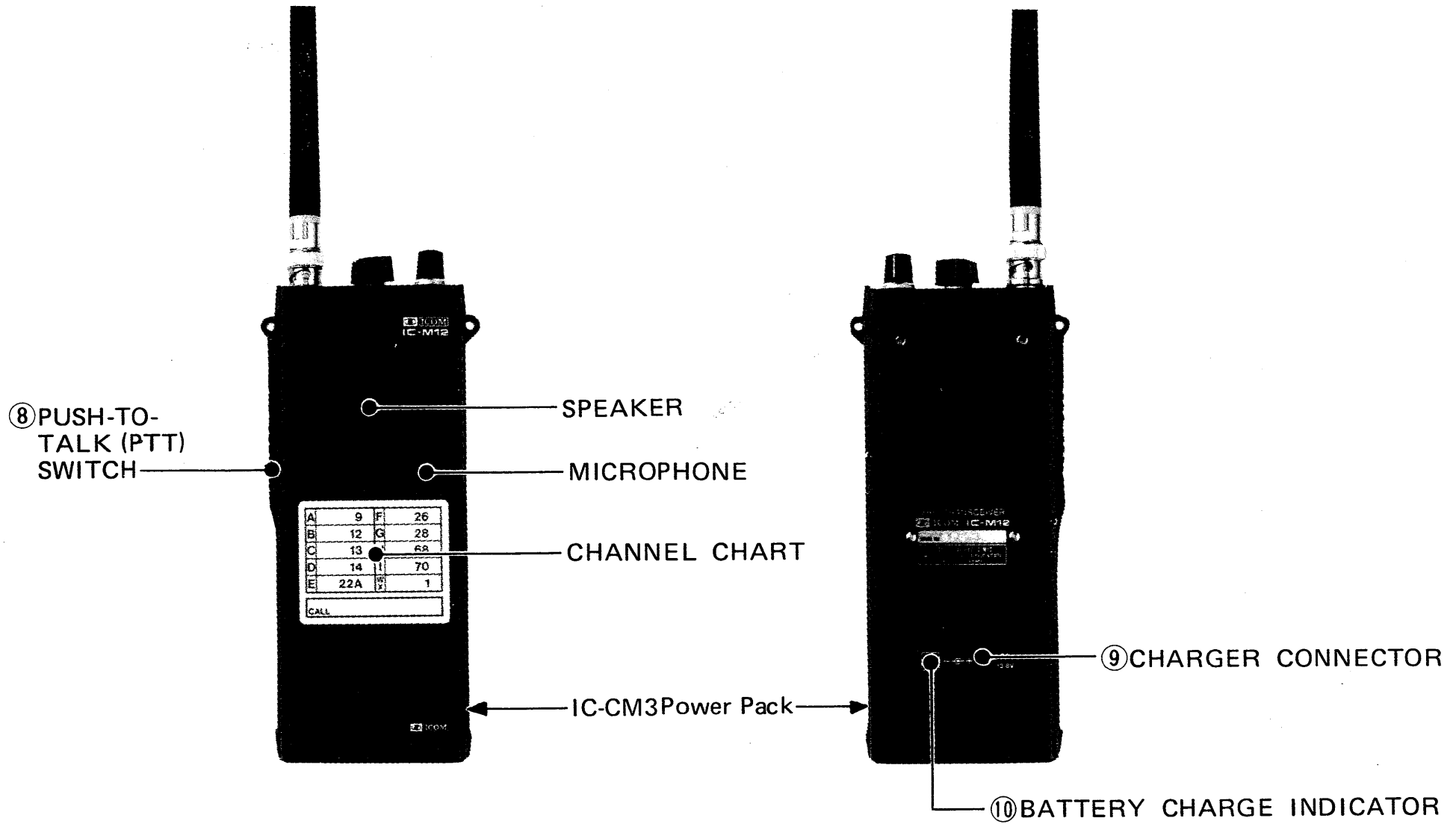

① **ANTENNA CONNECTOR**

Connect the supplied flexible antenna. An external antenna can be used, using a BNC connector.

② **TRANSMIT/BATTERY INDICATOR**

Illuminates in the transmit mode. Also indicates the battery condition; during transmission. The voltage of Nickel-Cadmium batteries drops rapidly just before they are exhausted, so when this indicator goes out, be sure to immediately stop using it, and charge the batteries again.

③ **CHANNEL SELECT SWITCH**

Selects one of the programmed channels.

④ **SQUELCH CONTROL**

Sets the squelch threshold level. To turn OFF the squelch function, rotate this control completely counterclockwise. To set the threshold level higher, rotate the control clockwise.

⑤ **VOLUME CONTROL and POWER SWITCH**

When the control is turned completely counterclockwise, the power is OFF. By turning the control clockwise beyond the "click", the unit is turned ON and the audio level increases by further rotating it clockwise.

⑥ **EXTERNAL SPEAKER JACK**

When an external speaker (or an earphone) is used, connect it to this jack. Use a speaker with an impedance of 8 ohms. When the external speaker is connected the built-in speaker does not function.

⑦ **EXTERNAL MIC JACK**

When an external microphone is used, connect it to this jack. See the schematic for the proper



hookup. When the external microphone is connected the built-in microphone does not function. The IC-CM9 optional speaker-microphone can also be used.

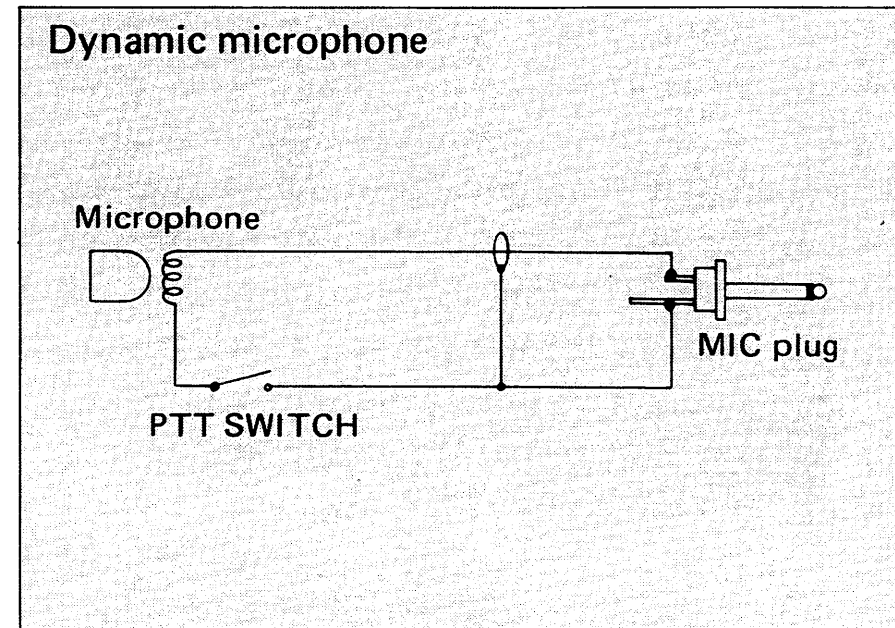
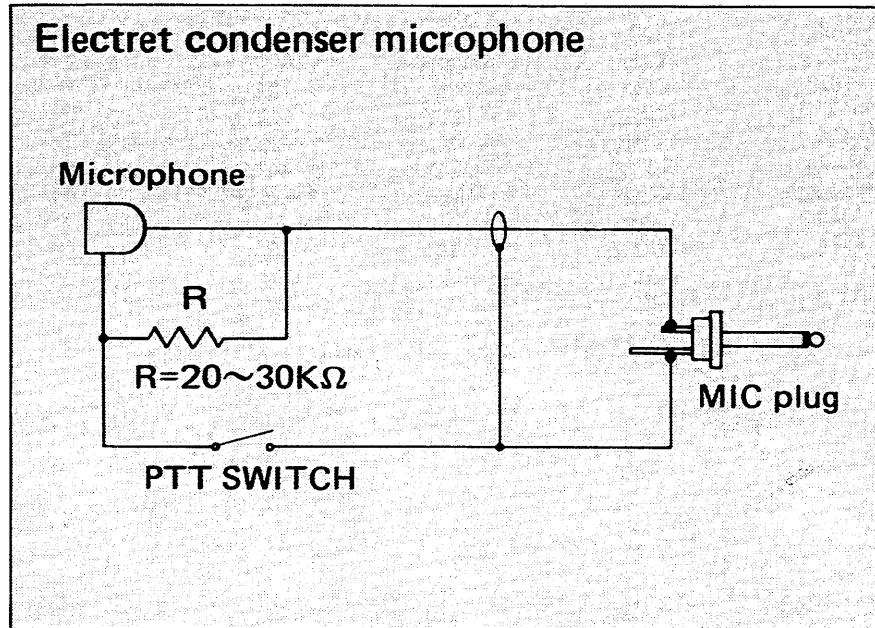

⑧ **PUSH TO TALK (PTT) SWITCH**

For transmission, press this switch and talk into the microphone with normal voice. The internal microphone is of the electret-condenser type and provides good pickup for all levels of voice.

⑨ **CHARGER CONNECTOR**

Connects to the output plug of the wall charger CM-25U/E or other 12V DC power source.

⑩ **BATTERY CHARGE INDICATOR**

Lights during battery charging.

## SECTION VI OPERATION

### RECEIVING

Make sure the ⑤ VOLUME CONTROL and POWER SWITCH is in the OFF position, and before turning ON the power switch, confirm as follows:

1. Make sure the power pack is properly charged and attached to the set.
2. Make sure the supplied flexible antenna is properly set.  
When an external antenna is employed, make sure the coaxial line is of the correct impedance (50 ohms) and is neither shorted nor opened, and is firmly connected to the antenna connector.

Set the controls and switches as follows:

- |                                   |  |
|-----------------------------------|--|
| ④ SQUELCH CONTROL                 | Completely counterclockwise                |
| ⑤ VOLUME CONTROL and POWER SWITCH | Completely counterclockwise (OFF position) |
| ③ CHANNEL SELECT SWITCH           | Desired channel                            |

Turn the ⑤ VOLUME CONTROL and POWER SWITCH clockwise (it will "click" ON) to a comfortable audio level.

If only noise can be heard and no signal, turn the ④ SQL control clockwise until the noise from the speaker stops and set it just below this threshold. (When adjusting the SQL setting, if some communication signals can be heard, turn the CHANNEL SELECT switch and set it where only noise can be heard.) You transceiver will now remain silent until an incoming signal is received which opens the squelch. If the squelch is unstable due to the reception of weak signals, adjust the squelch control further until the proper threshold is obtained.

If you wish to monitor one of the channels installed, simply rotate the Channel Select switch to the proper channel.

If you wish to monitor the Weather channel, simply set the Channel Select switch to the weather (WX) channel (or the letter channel with weather channel installed).

## **TRANSMITTING**

Set the controls and switches at the same positions as receiving.

Rotate the Channel Select Switch until you find an empty channel that can be used for the type of communication you wish. Be sure the channel is open.

Then set the Channel Select switch to the Channel 16, and after confirming that it is open, call the party you wish to contact. When contact is made, go to the channel you checked before. (Don't turn the Channel Select switch during transmission.)

Hold the transceiver fairly close to your mouth. Depress the ⑧ PTT switch and speak in a clear, natural voice. When you have finished your part of the conversation, release the PTT switch, and the radio will receive.

When your conversation is completely finished, set the Channel Select switch to the Channel 16.

## SECTION VII OPERATING RULES AND GUIDELINES

### Prevent Interference

Before transmitting, monitor the channel you wish to use to avoid interrupting transmissions in progress.

### Call Procedures

Calls must be properly identified and time limits must be respected.

1. Give your call sign each time you place a call to another vessel or a coast station. (If a call sign has not been assigned, identify the station by announcing the vessel name and the name of the licensee.)
2. Give your call sign at the end of each transmission of more than 3 minutes duration.
3. You must break and give your call sign at least once every fifteen minutes during long ship to shore calls.
4. Keep your unanswered calls short (less than thirty seconds) and do not repeat a call for two minutes.
5. Unnecessary Transmissions are not allowed.

### Priorities

Read all the rules and regulations pertaining to priorities and keep an up-to-date copy handy. Safety and Distress take priority over all others.

You must monitor and be able to transmit on 156.8MHz, Channel 16.

False or fraudulent distress signals are prohibited and punishable by law!

### Privacy

Information overheard but not intended for you cannot lawfully be used in any way. Indecent or profane language is prohibited.

### Logs

Use of this equipment required entry of the watch period of 156.8MHz (CH 16) by the operator with vessel name, call sign and operator signature. All distress, emergency, and safety messages must be recorded in complete detail. Log date activity is usually recorded in 24 hour time. Universal Time (formerly GMT) is frequently used.

Adjustments, repairs, channel frequency changes and authorized modifications affecting electrical operation of the equipment must be kept in the equipment log and entries signed by the authorized licensed technician performing or supervising the work. This is done in the equipment log, a small section is included in the back of this manual. Contacts are recorded in a communication log. A sample of what would be on the page is shown below.

DATE/TIME	CHANNEL	VESSEL	REMARKS	OPERATOR

## **Channel usage**

A channel selection system, frequency-usage, has been internationally adapted for the marine VHF band. Each frequency within the spectrum has been assigned a channel number, for example, 156.300 is Channel 6. Specific purposes have been assigned to each channel under this system i.e. inter-ship between two vessels and ship-to-shore. Geographical locations have specific channels assigned for use with the land telephone system.

Your selection of channels to be installed should be based on the type of contacts you plan to make within the areas you live or travel to. The chart on the following pages will aid this selection.

Each geographical area has specific channels assigned to it for use with the land telephone system.

Be sure to review the channels you should have installed in your radio to give you the capability to make the type of contacts you want in the area where you live or plan to travel.

Study the chart on the following pages, showing the available channels and their usage.

## **Dead Spots**

Topography may prevent reception and/or transmission from some locations. Move to another location if you find a "dead spot".

## **Routine Maintenance**

Your ICOM transceiver is designed to provide high quality performance for many years if cared for in a proper manner. Each year you should have the following checked by a licensed technician to verify your unit's performance.

1. Check antenna system.
2. Verify transmitter frequency, deviation, and power output.

# SECTION VIII MARINE VHF RADIOTELEPHONE CHANNEL FREQUENCIES

Channel	Ship Transmit	Ship Receive	Mode S/D	Only Intl	Only Com	USCG	Function		Type of Operation
							Ship - Ship	Ship to Shore	
1	156.050	160.650	D	yes			no	yes	Public Correspondence, Port Operation
2	156.100	160.700	D	yes			no	yes	Public Correspondence, Port Operation
3	156.150	160.750	D	yes			no	yes	Public Correspondence, Port Operation
4	156.200	160.800	D	yes			no	yes	Public Correspondence, Port Operation
5	156.250	160.850	D	yes			no	yes	Public Correspondence, Port Operation
6	156.300	156.300	S				yes	no	Safety
7	156.350	160.950	D		yes		no	yes	Public Correspondence, Port Operation
7A	156.350	156.350	S		yes		yes	yes	Port Operation
8	156.400	156.400	S		yes		yes	no	Intership
9	156.450	156.450	S				yes	yes	Port Operation
10	156.500	156.500	S		yes		yes	yes	Port Operation
11	156.550	156.550	S		yes		yes	yes	Port Operation
12	156.600	156.600	S				yes	yes	Port Operation
13	156.650	156.650	S				yes	yes	Bridge to Bridge, (1W) Navigational
14	156.700	156.700	S				yes	yes	Port Operation
15		156.750	S				Rcv	Rcv	Recv Only - Coast to Ship
16	156.800	156.800	S				yes	yes	Calling & Safety
17	156.850	156.850	S				no	yes	State Controlled - Ship to Coast (1W)
18	156.900	161.500	D	yes			no	yes	Port Operation
18A	156.900	156.900	S		yes		yes	yes	Port Operation
19	156.950	161.550	D	yes			no	yes	Port Operation
19A	156.950	156.950	S		yes		yes	yes	Port Operation
20	157.000	161.600	D				no	yes	Port Operation
21	157.050	161.650	D	yes			no	yes	Port Operation
21A	157.050	157.050	S			yes	yes	yes	Port Operation (USCG)
22	157.100	161.700	D	yes			no	yes	Port Operation
22A	157.100	157.100	S			yes	yes	yes	Port Operation (USCG)
23	157.150	161.750	D	yes			no	yes	Public Correspondence
23A	157.150	157.150	S			yes	yes	yes	Port Operation (USCG)
24	157.200	161.800	D				no	yes	Public Correspondence
25	157.250	161.850	D				no	yes	Public Correspondence
26	157.300	161.900	D				no	yes	Public Correspondence
27	157.350	161.950	D				no	yes	Public Correspondence
28	157.400	162.000	D				no	yes	Public Correspondence

Channel	Ship Transmit	Ship Receive	Mode S/D	Only Intl	Only Com	USCG	Function		Type of Operation
							Ship - Ship	Ship to Shore	
60	156.025	160.625	D	yes			no	yes	Public Correspondence, Port Operation
61	156.075	160.675	D	yes			no	yes	Public Correspondence, Port Operation
62	156.125	160.725	D	yes			no	yes	Public Correspondence, Port Operation
63	156.175	160.775	D	yes			no	yes	Public Correspondence, Port Operation
64	156.225	160.825	D	yes			no	yes	Public Correspondence, Port Operation
65	156.275	160.875	D	yes			no	yes	Public Correspondence, Port Operation
65A	156.275	156.275	S				yes	yes	Port Operation
66	156.325	160.925	D	yes			no	yes	Public Correspondence, Port Operation
66A	156.325	156.325	S				yes	yes	Port Operation
67	156.375	156.375	S		yes		yes	no	Port Operation
68	156.425	156.425	S				yes	yes	Port Operation
69	156.475	156.475	S				no	yes	Port Operation
70	156.525	156.525	S				yes	no	Intership
71	156.575	156.575	S				no	yes	Intership, Port Operation
72	156.625	156.625	S				yes	no	Intership
73	156.675	156.675	S				yes	yes	Port Operation
74	156.725	156.725	S				yes	yes	Port Operation
77	156.875	156.875	S		yes		yes	no	Intership
78	156.925	161.525	D	yes			no	yes	Port Operation
78A	156.925	156.925	S				no	yes	Port Operation
79	156.975	161.575	D	yes			no	yes	Port Operation
79A	156.975	156.975	S		yes		yes	yes	Port Operation
80	157.025	161.625	D	yes			no	yes	Port Operation
80A	157.025	157.025	S		yes		yes	yes	Port Operation
81	157.075	161.675	D	yes			no	yes	Port Operation
81A	157.075	157.075	S			yes	yes	yes	Port Operation (USCG)
82	157.125	161.725	D	yes			no	yes	Port Operation, Public Correspondence
82A	157.125	157.125	S			yes	yes	yes	Port Operation (USCG)
83	157.175	161.775	D	yes			no	yes	Public Correspondence
83A	157.175	157.175	S			yes	yes	yes	Intership, Port Operation (USCG)
84	157.225	161.825	D				no	yes	Port Operation, Public Correspondence
85	157.275	161.875	D				no	yes	Public Correspondence
86	157.325	161.925	D				no	yes	Public Correspondence
87	157.375	161.975	D				no	yes	Public Correspondence
88	157.425	162.025	D	yes			no	yes	Public Correspondence
88A	157.425	157.425	S		yes		yes	no	Intership
WX1		162.550					Rcv	Rcv	NOAA Weather (Rcv Only)
WX2		162.400					Rcv	Rcv	NOAA Weather (Rcv Only)
WX3		162.475					Rcv	Rcv	NOAA Weather (Rcv Only)
WX4(21R)		161.650					Rcv	Rcv	Canada Weather (Rcv Only)



**TRANSMITTER LOG**

Radio Set Serial No.	Date (Initial Reading)	Date	Date	Date	Date	Date	Date
Transmitter RF Power Output							
Transmitter Deviation							
Transmitter Frequency CH16							
Transmitter Frequency CH6							
<b>TECHNICIAN SIGNATURE,                  ADDRESS, FCC LICENSE NO.,                  EXPIRATION DATE</b>							

### TRANSMITTER LOG

	Date	Date	Date	Date	Date	Date	Date
Transmitter RF Power Output							
Transmitter Deviation							
Transmitter Frequency CH16							
Transmitter Frequency CH6							
TECHNICIAN SIGNATURE, ADDRESS, FCC LICENSE NO., EXPIRATION DATE							

## EMERGENCY USE

If your vessel requires assistance, attract the attention of other vessels and the Coast Guard by sending a distress message on Channel 16.

Procedures for sending a distress signal.

1. MAYDAY, MAYDAY, MAYDAY (repeat three times)
2. THIS IS (name of the vessel)
3. LOCATED AT (gives position)
4. Give the reason for the distress call.
5. Explain what assistance you need.
6. Give additional information to help those come to your assistance, (vessel length, color, type, etc.)
7. Use Channel 16 only to make initial contact.
8. After making initial contact agree on an alternate frequency, such as Channel 22A or Channel 6 and clear Channel 16 for other traffic.

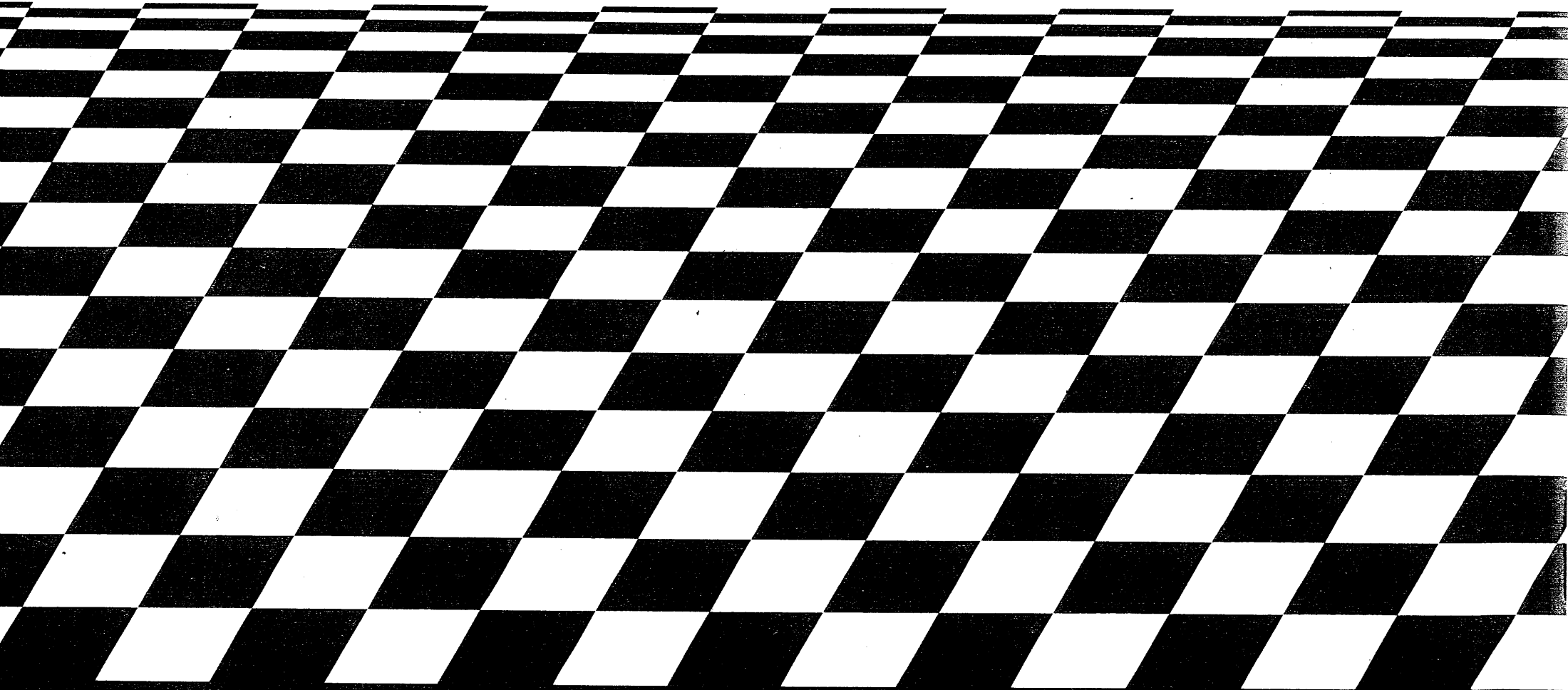

**ICOM INCORPORATED**

1-6-19, KAMI KURATSUKURI, HIRANO-KU  
OSAKA JAPAN

Printed in Japan